

# Greater Midwest Rotorcraft Club



## Monthly Newsletter

In B&W (color version available online)

July 2009

### Next Club Meeting

**Date:** Friday, July 24<sup>th</sup>

**Business Meeting:**

**Time:** 7:00 pm – 7:30 pm

**General Club Meeting:**

**Time:** 7:30 pm - ?

**Place:** Joe's Office

Lower-level Conference Room  
120 East Ogden Avenue  
Hinsdale, IL 60521

**Agenda Topic(s):**

- *Oshkosh Plans*
- *Mentone Plans*
- *Club Tractor Gyro Project*

Below is a preliminary scale drawing. It has since been decided by the build team that the gyro will have 2 masts – one in front of the seat as shown in the drawing, and one behind the seat like a standard Bensen. Brian Burke has recently purchased a Bensen airframe, and Tom Milton has a set of Bensen cheek plates. The plan for now is to assemble a flying prototype using this airframe, adding a second mast and engine mount.

Once we come up with a design which is proven to fly well, we can draw the gyro in auto cad and offer the design to the general public, much like Ralph Taggart did with the Gyrobee. If you are interested in participating in this project, come to the club hangar on Wednesday nights. If you have a long ride, you may want to call Adam Helwich or Brian Burke (numbers listed below) to make sure that there will be a build night that week.

Our last club project was a lot of fun and resulted in a great design, lets hope this one turns out even better.

### New Club Project – Tractor Gyro

In the past few years, there has been a lot of interest in small tractor gyroplanes. The Little Wing, which has set multiple gyroplane world records, is a great example of a small, homebuilt tractor gyroplane. The problem with its design is that it requires welding, which requires welding skill and jigs. The other issue is that it is enclosed. There are most likely many pilots who would enjoy flying an inherently stable tractor gyroplane, but still keep the out in the open feeling that a standard, pusher gyro affords.

Here is where the new club project gyro comes in; a small, easy to build tractor gyroplane put together using standard Bensen building methods – 2x2 aluminum square tube, cheek plates, angle.

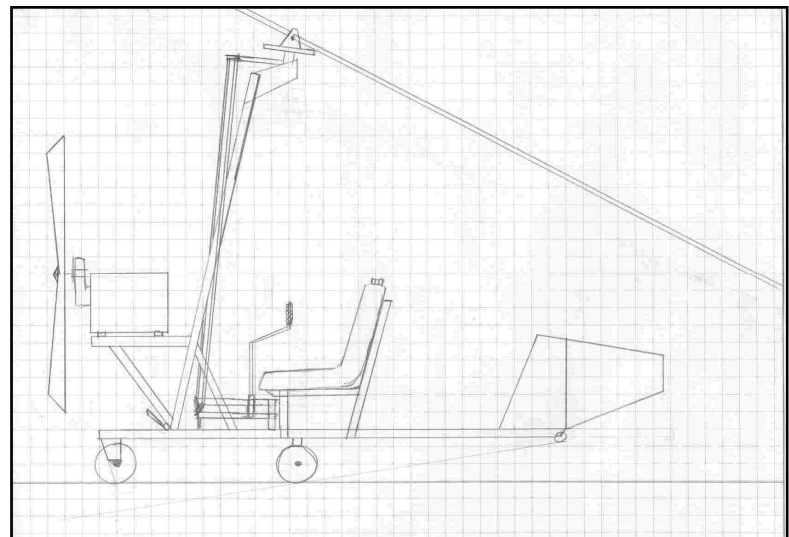

**President**

Joe Mahr  
(630) 325-0505

**Vice President**

Adam Helwich  
(708) 912-1624

**Treasurer**

Brian Burke  
(630) 953-8734

**Secretary**

Andy Svehla  
(630) 251-0802

**Guru/Sergeant at Arms**

Thomas D Milton  
(708) 785-0344

## Oshkosh Plans

Oshkosh will be going on this year from July 27<sup>th</sup> through August 2<sup>nd</sup>. If there is enough interest, the club will rent a van and drive to the air show as in years past. If you are interested in making a one day trip up to Oshkosh with the club, please contact Joe Mahr at (630) 325-0505.

## Mentone Plans

The PRA's annual convention will be held in Mentone once again this year. It will be held from August 4<sup>th</sup> through the 8<sup>th</sup> with the annual awards banquet being held on Saturday night. Some come for the whole week while others just come on Saturday. Either way, it is a great time and definitely worth the short drive. As in years past, we will have our club tent set up on the flight line. Hope to see you there!

## Kankakee Fly-In

On Saturday, the 11<sup>th</sup> of July a few club members ventured out to a fly-in being held at the Kankakee Airport. There were many ultralights and even more powered parachutes and powered paragliders. This would be a great event for a few gyros to attend next year. The pictures to the right are from the fly-in.

